

EN | Ultra flat ultrasonic motion and presence sensor

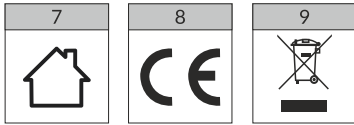

EN| Directions for safety use

Before connecting and using the device, read this Operating Manual and keep it for future reference. In case something written herein is unclear, please contact the seller. The manufacturer is not responsible for any damage that can result from improper device installation or operation. Any repair or modification carried out by yourselves results in loss of guarantee. In view of the fact that the technical data are subject to continuous modifications, the manufacturer reserves a right to make changes to the product characteristics and to introduce different constructional solutions without deterioration of the product parameters or functional quality. Additional information about ORNO products is available at www.orno.pl. Orno-Logistic Sp. z o.o. holds no responsibility for the results of non-compliance with the provisions of the present Manual. Orno Logistic Sp. z o.o. reserves the right to make changes to the Manual - the latest version of the Manual can be downloaded from support.orno.pl. Any translation/interpretation rights and copyright in relation to this Manual are reserved.

1. Installation must be carried out by an electrician or an experienced person.
2. Disconnect the power supply before any activities on the product.
3. Do not immerse the device in water or other fluids.
4. Do not operate the device when its housing is damaged.
5. Do not open the device and do not repair it by yourselves.
6. Do not use the device against its intended use.
7. The product is intended for indoor use.
8. Product compliant with CE standards.

9. Every household is a user of electrical and electronic equipment and therefore a potential producer of hazardous waste to humans and the environment from the presence of hazardous substances, mixtures and components in the equipment. On the other hand, waste equipment is a valuable material, from which we can recover raw materials such as copper, tin, glass, iron and others. The symbol of a crossed-out rubbish bin placed on the equipment, packaging or documents attached thereto indicates the necessity of separate collection of waste electrical and electronic equipment. Products marked in this way, under penalty of a fine, may not be disposed of in ordinary waste together with other waste. The marking also means that the equipment was placed on the market after the 13th August 2005. It is the user's responsibility to hand over the waste equipment to a designated collection point for proper treatment. Used equipment may also be returned to the seller in case of purchase of a new product in a quantity not greater than the new purchased equipment of the same type. Information about the available waste electrical equipment collection system can be found at the information point of the shop and in the municipal office. Proper handling of waste equipment prevents negative consequences for the environment and human health!

09/2024

DIMENSIONS

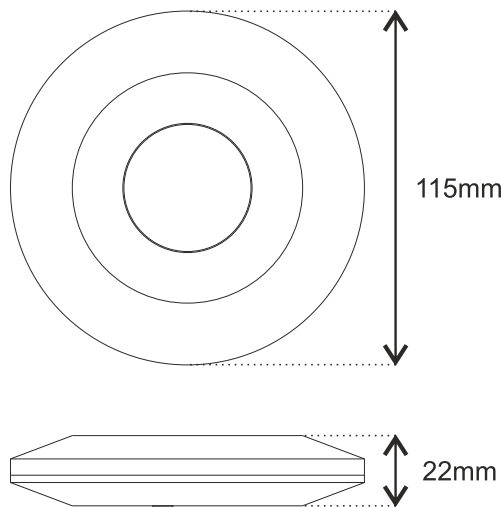

fig.1

WIRING DIAGRAM

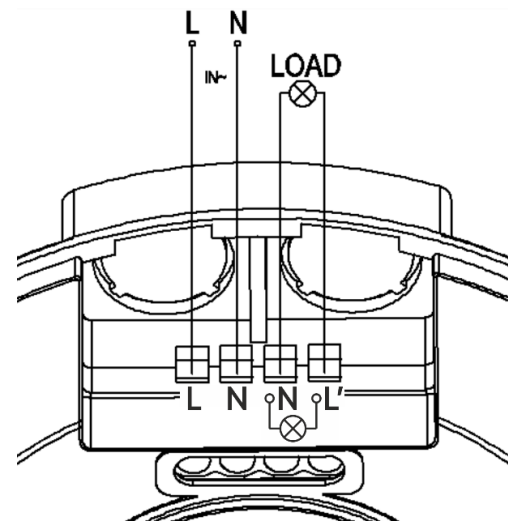

fig.2

DETECTION FIELD

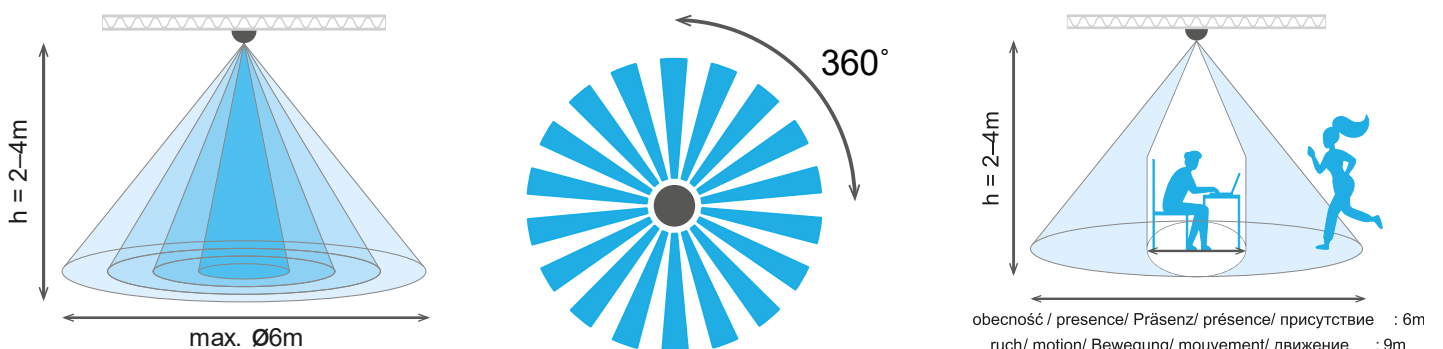

fig.3

obecność / presence/ Präsenz/ présence/ присутствие : 6m
 ruch / motion/ Bewegung/ mouvement/ движение : 9m

TECHNICAL DATA

Power supply	230V~, 50Hz
Max. load	☀ 2000W LED 500W
Operating frequency	24GHz
Power consumption during operation	0,5W
Detected object's speed	0,6 – 1,5m/s
Detection angle	360°
Adjustable daylight sensor	<3 – 2000lux
Adjustable time setting	10s±3s – 12min±1min
Detection range	motion ≤6m
	presence ≤9m
Installation height	2 – 4m
Protection level	IP20
Net weight	0,104kg
Working temperature	-20°C ~ +50°C
Dimensions	Ø115 x 22mm

EN

CHARACTERISTICS

A motion sensor is an advanced device that detects movement and has the capability to activate a lighting system to optimize electricity consumption. The device operates based on ultrasonic technology, which ensures precise motion and presence detection over large areas. The IP20 protection rating allows the sensor to be installed indoors in dry environments that are not exposed to dust and moisture. The device is designed for surface ceiling mounting. Connections are made using screw terminals, ensuring a stable and secure connection. The built-in dual sensors enhance the precision of motion detection. The adjustable light intensity threshold allows the device to be adapted to various lighting conditions. Additionally, the detection angle is 360°, providing complete monitoring coverage. Made from high-quality thermoplastic material, available in white.

NOTES

- When selecting a mounting location, consider the angle and detection range of the sensor. The range and efficiency of the sensor depend on the mounting height, ambient temperature (ideal conditions: approx. 24°C, low humidity), and the direction of detected movement (the sensor detects movement across its field of view better than directly towards or away from the sensor).
- Avoid pointing the sensor towards: objects with highly reflective surfaces (e.g., mirrors), brightly illuminated objects (e.g., white surfaces), objects moving due to wind (curtains, tall plants), and areas where animal movement may be detected. These can negatively affect the sensor's performance.
- Do not mount the sensor near: strong sources of electromagnetic interference, heat sources, or areas with fluctuating temperatures (ventilation openings, air conditioners, lighting, or heating elements). These can also negatively impact sensor performance.
- Ensure that the power cables have appropriate current protection, such as proper fuses or other devices that disconnect the power in case of overload.
- Dirty sensor optics reduce the detection range and sensitivity. Clean the device according to the instructions.
- If the temperature difference between the moving object and the surroundings is small (e.g., in summer), the sensor may respond more slowly, and its detection range may decrease.
- Installation should be carried out by an electrician or an experienced person.
- Do not use unstable objects as a base for installation.
- Avoid placing objects that could interfere with the sensor's operation in front of the device.
- Do not open the housing after connecting the sensor to power.

INSTALLATION

1. Turn off the power supply.
2. Check the power-off state of the power supply wires with an appropriate device.
3. Turn the sensor cover counterclockwise and remove it from the sensor base.
4. Connect all electrical wires according to the wiring diagram.
5. Secure the sensor base in the chosen location using 2 screws.
6. Place the sensor cover back onto the base and turn it clockwise to close the device.
7. Turn on the power and test the sensor.

TEST

1. Turn off the power supply.
2. Set the TIME knob to the minimum position (10 seconds) and the LUX knob to the maximum position (☀).
3. Turn on the power supply. Wait 30 seconds for the sensor to calibrate. After this time, the sensor will function correctly:
 - upon detecting presence within a range of up to 3m, the receiver will be activated, and if no presence is detected within 10±3 seconds, the receiver will be turned off,
 - upon detecting movement within a range of up to 4.5m, the receiver will be activated, and if no movement is detected within 10±3 seconds, the receiver will be turned off.
4. Turn the LUX knob to the minimum position (3). If the ambient light intensity exceeds 3 LUX, the receiver controlled by the sensor should not activate. If the light intensity is below 3 LUX, the sensor will operate and turn on the receiver. If no movement is detected within the detection field, the sensor will automatically turn off the receiver within 10±3 seconds

Note: when testing the device in daylight, set the LUX knob to the maximum position (☀); otherwise, the sensor will not function correctly!

TROUBLESHOOTING

Load does not work:

- a. Check the power and receiver connections.
- b. Check the receiver.
- c. Check the sensor and twilight sensor settings.

Poor sensitivity:

- a. Check if there are any devices in front of the sensor that might interfere with the signals.
- b. Ensure the detected object is within the detection field.
- c. Check the installation height.

Sensor cannot automatically turn off the load:

- a. Check if there are continuous motion signals in the detection field.
- b. Check if the time delay is set to the maximum value.
- c. Ensure the power supply complies with the instructions.

SAFETY AND MAINTENANCE

Maintenance should be performed with the power off. Clean only with soft, dry cloths. Do not use chemical cleaning agents. Do not cover the product. Ensure free air access.